

# COFFING<sup>®</sup>

## HOISTS

# OPERATING & MAINTENANCE INSTRUCTIONS WITH PARTS LIST

Publication Part No. CB-680-7

## CB - Aluminum Hand Chain Hoist

*For Capacities:*

1 - 12 Ton



### IMPORTANT—CAUTION

To safeguard against the possibility of personal injury or property damage, follow the recommendations and instructions of this manual. This manual contains important information for the correct installation, operation, and maintenance of this equipment. All persons involved in the installation, operation, and maintenance of this equipment should be thoroughly familiar with the contents of this manual. Keep this manual for reference and further use.

### ⚠ WARNING

To prevent personal injury, do not use the equipment shown in this manual to lift, support, or otherwise transport people, or to suspend unattended loads over people.

**TABLE OF CONTENTS**

SECTION I	INTRODUCTION .....	3
1-1	General Information .....	3
1-2	Safety Standards .....	3
1-3	Hoist Construction .....	3
1-4	Basic Hoist Data .....	3
1-5	Application Information .....	3
1-6	Warranty .....	3
SECTION II	PREPARATION FOR USE .....	4
2-1	Safety Notes .....	4
2-2	Inspection Prior to Initial Use .....	4
2-3	Installation .....	4
2-4	Testing .....	4
SECTION III	OPERATION .....	4
3-1	General .....	4
3-2	Safety Notes .....	4
3-3	Attaching the Load .....	5
3-4	Lifting or Pulling the Load .....	5
3-5	Lowering the Load .....	5
SECTION IV	INSPECTION .....	5
4-1	General .....	5
4-2	Frequent Inspection .....	5
4-3	Periodic Inspection .....	5
4-4	Inspection of Hoist Not in Regular Use .....	6
4-5	Chain Inspection .....	6
4-6	Hook Throat Opening .....	6
SECTION V	MAINTENANCE .....	7
5-1	General .....	7
5-2	Lubrication .....	7
5-3	Chain Replacement .....	8
5-4	Thread Stop Adjustment .....	8
SECTION VI	SERIAL NUMBER AND PARTS LIST .....	11
6-1	Serial Number .....	11
6-2	Design Series .....	12
6-3	How to Order Replacement Parts .....	12
6-4	Parts List .....	12
SECTION VII	EXPLODED ILLUSTRATION .....	15
Figure 7-1	CB-1-1½-2-3 Ton Hoist .....	15
Figure 7-2	CB-4 Ton Hoist .....	16
Figure 7-3	CB-5-6 Ton Hoist .....	17
Figure 7-4	CB-8-10-12 Ton Hoist .....	18
SECTION VIII	DO'S AND DO NOT'S .....	19

**SECTION I  
INTRODUCTION**

**1.1 GENERAL INFORMATION**

This manual provides information for the safe operation and maintenance of coffering CB Series Aluminum Hand Chain Hoist. All persons operating or maintaining these hoists should be familiar with the information contained herein. Adherence to the precautions, procedures, and maintenance practices described should ensure long reliable operation. Suggestions for improvements to this manual are solicited.

**1.2 SAFETY STANDARDS**

All persons concerned with the installation operation, inspection and maintenance of this hoist are urged to read American National Standard ANSI B30.16. That standard contains important rules (some mandatory and some of an advisory nature) designed primarily to prevent or minimize injury and otherwise protect life, limb and property. You should especially be aware of the mandatory rules pertaining to inspection requirements and the advisability of maintaining written, dated and signed inspection reports and records. All applicable state and local codes for this product should be observed also.

**1.3 HOIST CONSTRUCTION**

This Coffering Hoist has a strong, relatively lightweight aluminum housing for portability. The CB Hand Chain Hoist employs the Superoid gear transmission for strength and efficiency. Superoid gearing puts more teeth into contact under load than any other system of hoist gearing. Fewer parts are used, giving you increased hoist life and reducing maintenance. Gearing is made from alloy steel forgings. Outriggers, chain guides, and shedders are malleable iron. Hooks are steel forgings and Load Chain is heat treated alloy steel. The Hand Chain Wheel is one piece construction of aluminum alloy.

**1.4 BASIC HOIST DATA**

The operator should be aware of the Basic Hoist Data in Table I.

**1.5 APPLICATION INFORMATION**

This hoist is intended for general industrial use for lifting, pulling, and tensioning-type applications within its rated load. Prior to installation and operation, the user should review his application for abnormal environmental or han-

dling conditions and to observe the applicable recommendations as follows:

a. **Adverse Environmental Conditions** Do not use the hoist in areas containing flammable vapors, liquids, gases or any combustible dusts or fibers. Refer to Article 500 of *The National Electric Code*. Do not use this hoist in highly corrosive or abrasive environments. Do not use this hoist in applications involving extended exposure to ambient temperatures below -10°F or above 130°F.

b. **Lifting of Hazardous Loads** This hoist is not recommended for use in lifting or transporting hazardous loads or materials which could cause wide-spread damage if dropped. The lifting of loads which could explode or create chemical or radioactive contamination if dropped requires fail-safe redundant supporting devices which are not incorporated into this hoist.

**1.6 WARRANTY**

Every hoist is thoroughly inspected and tested prior to shipment from the factory. Should any problems develop, return the complete hoist prepaid to your nearest Duff-Norton Authorized Warranty Repair Station. If inspection reveals that the problem is caused by defective workmanship or material, repairs will be made without charge and the hoist will be returned, transportation prepaid.

This warranty does not apply where: (1) deterioration is caused by normal wear, abuse, improper or inadequate power supply, eccentric or side loading, overloading, chemical or abrasive actions, improper maintenance or excessive heat; (2) problems resulted from repairs, modifications or alterations made by persons other than factory or Duff-Norton Authorized Warranty Repair Station personnel; (3) the hoist has been abused or damaged as a result of an accident; (4) repair parts or accessories other than those supplied by Duff-Norton Company are used on the hoist. Equipment and accessories not of the seller's manufacture are warranted only to the extent that they are warranted by the manufacturer. EXCEPT AS STATED HEREIN, DUFF-NORTON COMPANY MAKES NO OTHER WARRANTIES, EXPRESS OR IMPLIED, INCLUDING WARRANTIES OF MERCHANTABILITY AND FITNESS FOR A PARTICULAR PURPOSE.

**TABLE 1. Basic Hoist Data**

Model Number	Rated Load (Lb.)	Standard Lift (Ft.)	Approx. Net Wt. (Lb.)	Min. Dist. Between Hooks, (In.)	Feet of Chain Overhauled to Lift Load One Ft.	Chain Pull In Lbs. to Lift Rated Load	Strands of Load Chain
CB-1	2000	8	38	13 <sup>3</sup> / <sub>8</sub>	38	58	1
CB-1½	3000	8	58	18½	58	62	1
CB-2	4000	8	58	18½	58	83	1
CB-3	6000	8	78	21½	85	91	1
CB-4	8000	8	98	25¼	116	85	2
CB-5	10000	8	127	26¾	174	72	3
CB-6	12000	8	127	26¾	174	87	3
CB-8	16000	8	160	28½	232	90	4
CB-10	20000	8	212	31	340	83	4
CB-12	24000	8	212	31	340	100	4

## SECTION II PREPARATION FOR USE

### 2.1 SAFETY NOTES

a. The supporting structure and load attaching devices should have a load rating at least equal to that of the hoist.

b. This hoist is not suitable for use in locations or areas containing explosive dust, vapors or gases.

c. The installation area must provide safe operating conditions for the operator, including sufficient room for the operator and other personnel to stand clear of the load at all times.

### 2.2 INSPECTION PRIOR TO INITIAL USE

Inspect the hoist for any evidence of shipping damage or loose parts. Perform the frequent inspections listed in paragraph 4.2. This should be done by or under the direction of a person familiar with hoist operation and industrial safety standards prior to initial use. All inspections of any kind should be logged or recorded, dated, signed and filed for reference purposes.

### 2.3 INSTALLATION

a. Secure the hoist to a suitable supporting member by use of the top hook. Make sure that the hook latch is closed. Apply a small amount of H-7593 grease or equivalent between the hook and supporting member.

#### CAUTION:

b. **Do not side load the hoist or restrict the housing or chain from forming a straight line with the direction of loading.**

### 2.4 TESTING

Check the hoist through a few lifting and lowering cycles with no load on the hook. Attach a load of fifty pounds to the hook and check the hoist through a few lifting cycles. Operate the hand chain in the up and down direction. If operation is normal with this light load, test the hoist for operation with rated load, and then with about 125 percent of rated load.

Americrane & Hoist Corp 1-800-652-1932

## SECTION III OPERATION

### 3.1 GENERAL

This section presents information concerning the proper operation of the Coffing® CB-Series Hoist. It is not intended to serve as a handbook on rigging. Rigging, the process of moving heavy loads using mechanical devices, requires special knowledge and equipment. For information on the safe use of slings and similar rigging gear, users are urged to consult a textbook on rigging.

### 3.2 SAFETY NOTES

Inspect the hoist for any sign of loose, broken, or malfunctioning parts (see Section IV). Any malfunctioning hoist should be tagged as "out of order" and removed from service until the defect is corrected.

a. Do not overload the hoist.

b. Do not exert more than the hand chain pull to lift rated load by one operator (see Table I). The Hoist is designed to lift its rated capacity when a reasonable force is exerted. If effort appears to be excessive, recheck the load and use a larger capacity hoist if necessary.

c. Do not side load the hoist. Always pull in a straight line between hooks. Side loading over a sharp corner may fracture the hoist housing or load block.

d. Be sure there are no twists in the load chain and make sure that load chain is free to move and will clear all obstructions. On multiple chained hoist it is possible for the load block to be capsized or turned over one or more times causing the chain to twist.

e. Do not operate the hoist from an off balance position. Operator should have firm footing or be otherwise secured before operating the hoist.

f. Before raising or pulling a load, always check to see that it is held securely in the hook or sling chains, etc. Raise the load only until the load chain is taut and then recheck the rigging before continuing to raise the load.

g. Make sure that the slings and other rigging have sufficient capacity to support the load, and are in good condition.

h. **DO NOT STAND BENEATH A LOAD!** Do not move a load in such a manner as to endanger personnel.

i. Do not leave the hoist under load for extended or unattended periods unless specific precautions have been taken to provide protection.

j. Do not wrap the load chain around a load. **USE A SLING!**

k. Do not **TIP-LOAD** any hook, as this will exert undue strain in the hook, resulting in hook failure.

l. The CB Series of hoists are designed for manual operation by one person. Do not attempt to operate hoist with other than the manual power furnished by one person.

m. **DO NOT USE HOIST TO LIFT, SUPPORT OR OTHERWISE TRANSPORT HUMAN CARGO.**

### 3.3 ATTACHING THE LOAD

Attach the load to the hook by means of slings or other approved devices. Make sure the slings or other devices are seated properly in the saddle of the hook before lifting. Be sure the hook latch is closed and working properly. Never wrap the load chain around the load.

### 3.4 LIFTING OR PULLING THE LOAD

To raise the load pull hand chain downward in a clockwise direction while facing the hand chain wheel housing. Take note of the following when lifting the load:

a. Lift or pull the load a few inches and check to see that it is well balanced in the sling or other lifting device. Make sure the load chain is not kinked or twisted or that the load does not contact any obstruction.

b. Lift or pull the load to the desired distance. Do not leave the hoist under load for extended or unattended periods unless specific precautions have been taken to provide protection.

### 3.5 LOWERING THE LOAD

To lower the load pull hand chain downward in a counter-clockwise direction while facing the hand chain wheel housing.

The end of the chain should not be allowed to pull on the dead end pin.

**CAUTION: Make sure that the slack end chain is free to move into the housing and will clear all obstructions. Do not extend bottom hook beyond the hoist rated lift.**

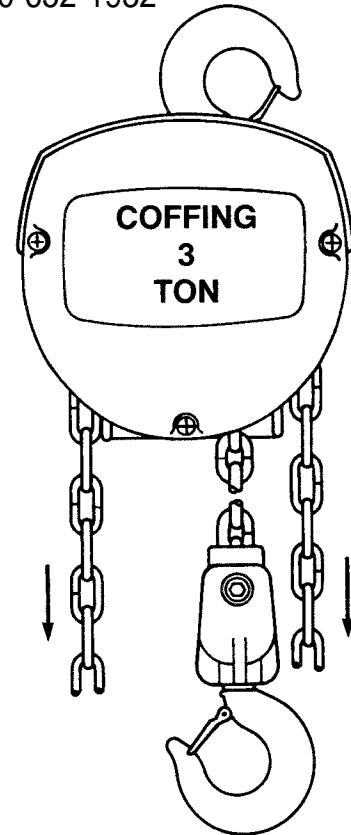

FIGURE 3-1. OPERATION

## SECTION IV INSPECTION

### 4.1 GENERAL

A planned inspection routine should be established for this hoist based upon frequency of use, severity of use, and environmental conditions. Some inspections should be made frequently (daily to monthly) and others periodically (monthly to yearly). It is strongly recommended that an Inspection and Maintenance Check List and an Inspector's Report similar to those shown in Figures 5-5 and 5-6 be used and filed for reference. All inspections should be made by, or under the direction of a designated inspector. Special inspections should be made following any significant repairs or any operating occurrence leading one to suspect that the hoist's capabilities may have been impaired.

The existence of well-worn parts is sufficient reason for questioning safe operation not to mention the added costs to repair damage that will inevitably result if severe wear is permitted to continue. The parts most likely to first evidence wear are: the chain, and sheave, hook's and brake area.

### 4.2 FREQUENT INSPECTIONS

**CAUTION: Any unsafe condition disclosed by the inspection shall be corrected before operation of the hoist is resumed. Adjustments and repairs shall be done only by designated personnel.**

Perform the following inspections daily prior to initial use of the hoist. Also, observe during operation for any damage which might appear between regular inspections. Prior to inspection, clean parts as required.

a. Inspect the hooks for deformations, chemical damage or cracks. Hooks damaged by chemicals, deformation or cracks, or having throat openings greater than the "Maximum Allowable Opening" shown in Figure 4-2 must be replaced. If the hook is twisted more than 10 degrees from the plane of the unbent hook, it must be replaced.

**NOTE: Any hook that is twisted or has throat openings in excess of those listed in Figure 4-2 indicates abuse or overloading of the hoist. Other load bearing components should be inspected accordingly.**

b. Check for missing, bent or otherwise damaged hook latches.

c. Check that hooks swivel freely.

d. Check the chain for elongation, see section 4.5. If the chain has been elongated the hoist has probably been highly overloaded. A qualified service man should inspect the hoist for other damage or send the hoist to an authorized repair facility nearest you.

e. Check load chain for gouges, nicks, weld spatter, corrosion and distorted links. Also check the chain for presence of foreign material and adequate lubrication.

f. Check load chain reeving per figure 5-4 making sure that there are no twists in the load chain.

g. Check that the dead end pin or connection is secure.

### 4.3 PERIODIC INSPECTIONS

It is recommended that the following inspections be performed at one- to twelve-month intervals. The exact period

of inspection will depend on frequency and type of usage. Determination of this period will be based on the user's experience. It is recommended that the user begin with a monthly inspection and extend the periods to quarterly, semi-annually or annually based on his monthly experience.

- a. Perform all the frequent inspections listed in paragraph 4-2.
- b. Check nuts, bolts and other hardware for looseness, stripped or damaged threads.
- c. Check load sheave and chain attachments for distortion, cracks and excessive wear.
- d. Check pawl for excessive wear, binding and worn bearing.
- e. Check pawl springs for breaks, corrosion and stretch.
- f. Check pawl stud for excessive wear and pawl retention.
- g. Inspect gear and pinion shaft for adequate lubrication, cracks, distortion, worn or broken teeth and damaged threads.
- h. Inspect bearings for adequate lubrication, distortion, cracks and excessive wear.
- i. Check housing, covers and swivel frames for cracks, distortion and damaged threads.
- j. Inspect the chain per paragraph 4-5.
- k. Check hooks for cracks using dye penetrant, magnetic particle or other suitable detection method.
- l. Load brake check ratchet and brake disc for excessive wear glazing or oil contamination.

#### 4.4 INSPECTION OF HOIST NOT IN REGULAR USE

If the hoist has been idle for one month or more, perform the inspections listed in paragraph 4-2. If the hoist has been idle more than six months, perform the inspections listed in paragraph 4-3.

#### 4.5 CHAIN INSPECTION

Chain inspection and lubrication are the most important aspects of hoist maintenance. Removal of the chain from the hoist usually is not necessary, but the chain should be run through the hoist enough that every link is made visible for inspection.

- a. Check each link for gouges, nicks, weld spatter, corrosion and distortion.
- b. Inspect each link for wear to the diameter of the link (see Figure 4-1). The nominal link diameter is .281 inch for the chain on model CB-1 and .375 inch for models CB1½, 2, 4, 5, 6 and 8. Models CB-3, 10 and 12 have nominal link diameter of .437 inch. If the diameter of any link of

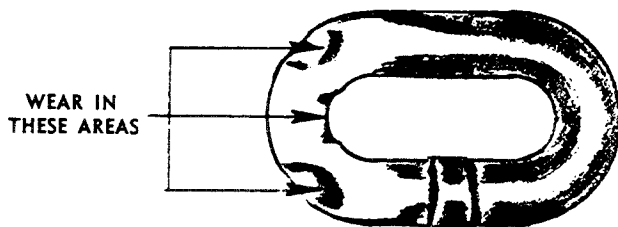

FIGURE 4-1 TYPICAL WEAR ON LINKS

.281 chain is worn to less than .225 or .375 chain less than .300 and .437 chain less than .350, the entire chain must be replaced.

c. 1.) Check the chain for overall wear or stretch by selecting an unworn, unstretched length of chain (at the slack end, for example). Let the chain hang vertically with a light load (about 20 lbs.) on the chain to pull it taut. Use a large caliper to measure the outside length of a convenient number of links (about 12 inches). Measure the same number of links in a used section of chain and calculate the percentage increase in length of the worn chain.

2.) If the length of the worn chain is more than 1½% longer than the unused chain (.015" per inch of chain measured), then the chain should be replaced. If the chain is worn less than 1½%, check it at several more places along its length. If any section is worn more than 1½%, the chain should be replaced.

d. The chain used in this hoist is accurately calibrated to operate over the load sprocket and is very carefully heat treated for maximum wear life and strength.

#### WARNING

1. Do not weld or use missing links to join hoist load chain.
2. Do not substitute another manufacturer's chain in this hoist.
3. Damage or wear, beyond the stated limits, to any portion of the chain requires that the entire length be replaced.

#### 4.6 HOOK THROAT OPENING

Use Figure 4-2 (below) to check maximum allowable hook throat opening.

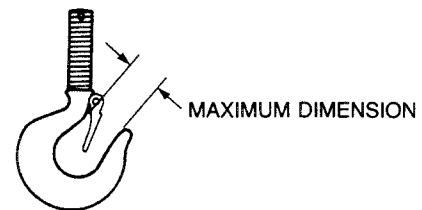

Americrane & Hoist Corp 1-800-652-1932

Cap. (Tons)	REJECT HOOK OPENING	
	Top	Bottom
1	1 <sup>7</sup> / <sub>32</sub> "	1 <sup>7</sup> / <sub>32</sub> "
1½ & 2	1 <sup>23</sup> / <sub>32</sub> "	1 <sup>23</sup> / <sub>32</sub> "
3 & 4	2 <sup>5</sup> / <sub>32</sub> "	2 <sup>5</sup> / <sub>32</sub> "
5 & 6	2 <sup>5</sup> / <sub>32</sub> "	2 <sup>5</sup> / <sub>32</sub> "
8	2 <sup>19</sup> / <sub>32</sub> "	2 <sup>19</sup> / <sub>32</sub> "
10 & 12	2 <sup>7</sup> / <sub>8</sub> "	2 <sup>7</sup> / <sub>8</sub> "

FIGURE 4-2. HOOK THROAT OPENING

## SECTION V MAINTENANCE

### 5.1 GENERAL

This section provides instructions for the most common routine maintenance and adjustments. Major repairs are not within the scope of this manual and should be referred to qualified service facilities.

### 5.2 LUBRICATION

Proper lubrication is necessary for a long and relatively trouble-free hoist operation. Refer to the following and to Figure 5-1. Recommended Lubrication Schedule, for lubrication points, type of lubricant and frequency of lubrication.

a. **LOAD CHAIN.** Clean the load chain with a non-acid and non-caustic solvent and coat with SAE 90 gear oil. Wipe excess oil to prevent dripping. If the hoist is used in an atmosphere containing abrasive dust, the chain should be cleaned and oiled more frequently. Never apply grease to the chain.

b. **BEARINGS.** Load Sheave and Pinion bearings are factory sealed and prelubricated for life.

c. **HOOKS.** Allow a little oil to run down the shank to lubricate between the shank and the swivel or load block of the bottom hook. The top hook shank should be lubricated in a like manner letting the oil run down the shank and onto the Top Hook Washer (55).

d. **LOAD BLOCK and OUTRIGGER.** For multiple chained hoists turn the Load Block on its side and allow a little oil to run down the Load Block shaft and into the roller bearings. Do this on both sides. Regrease bearings at least once yearly.

e. **GEAR SET.** Remove the old grease from the Superoid gear set at least once a year. (59 & 60). Apply H-7593 grease to the teeth of the gear set.

**NOTE:** When removing the gear from the hoist, do not lose the shim(s) (57) located between the gear and the bearing (61), as they control backlash of the Gear Set.

Americrane & Hoist Corp 1-800-652-1932

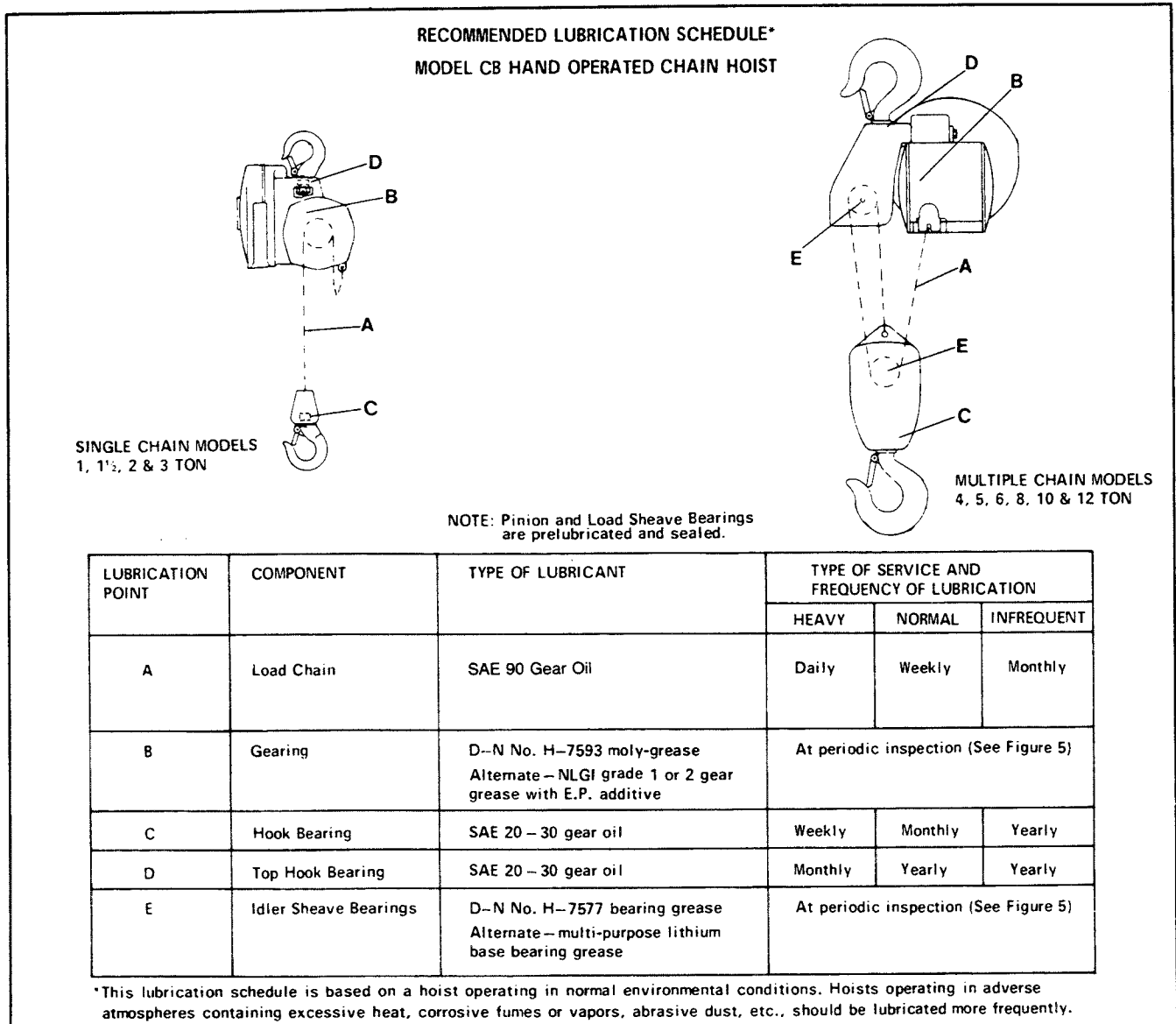

**FIGURE 5-1 RECOMMENDED LUBRICATION SCHEDULE**

### 5.3 CHAIN REPLACEMENT

a. If the chain has been removed from the hoist, and all inspection procedures have been followed, the chain should be installed in the hoist as follows:

b. Invert the hoist housing on a work table. Drop loose end of the load chain into the side of the Load Sheave facing the hoist cover. The first link of the chain should be upstanding in the load sheave groove, so that the weld on the link faces away from the Load Sheave (see Figure 5-2). The second link of the chain should ride in one of the load sheave pockets. Turn the Hand Chain Wheel to rotate sheave. As the end of the chain moves around the sheave, turn the hoist housing upright so the chain will be guided through the shedder clearance hole. Attach the first link to the dead-end lug of the Shedder, using the Dead End Pin. **DO NOT TWIST CHAIN!**

c. REMEMBER!

- 1) The weld on all upstanding chain links must face away from the Load Sheave.
- 2) The chain should not be twisted or kinked between the Load Sheave or the Dead End Lug or throughout the reeving process.

d. The chaining instructions above apply to all CB hoists, when reeving the load chain through the Load Sheave and is all the chaining necessary on capacities 1 Ton through 3 Ton, however the larger capacities also use idler sheaves. As above, after securing one end of the load chain to the Dead End Pin in the Shedder the other end of the chain is to be stretched out to be sure all links are straight (no twist or kinks) and the end reeved through the idler sheaves as shown in Figure 5-4. The idler sheaves are free turning so the chain can be worked through by turning the sheaves with a finger while feeding the chain in. This can also be done by attaching a wire to the end of the load chain and working it around the sheaves one at a time. When this end of the chain is properly reeved secure the end of the chain to the outrigger or the load block with the Dead End Screw as indicated in Figure 5-4.

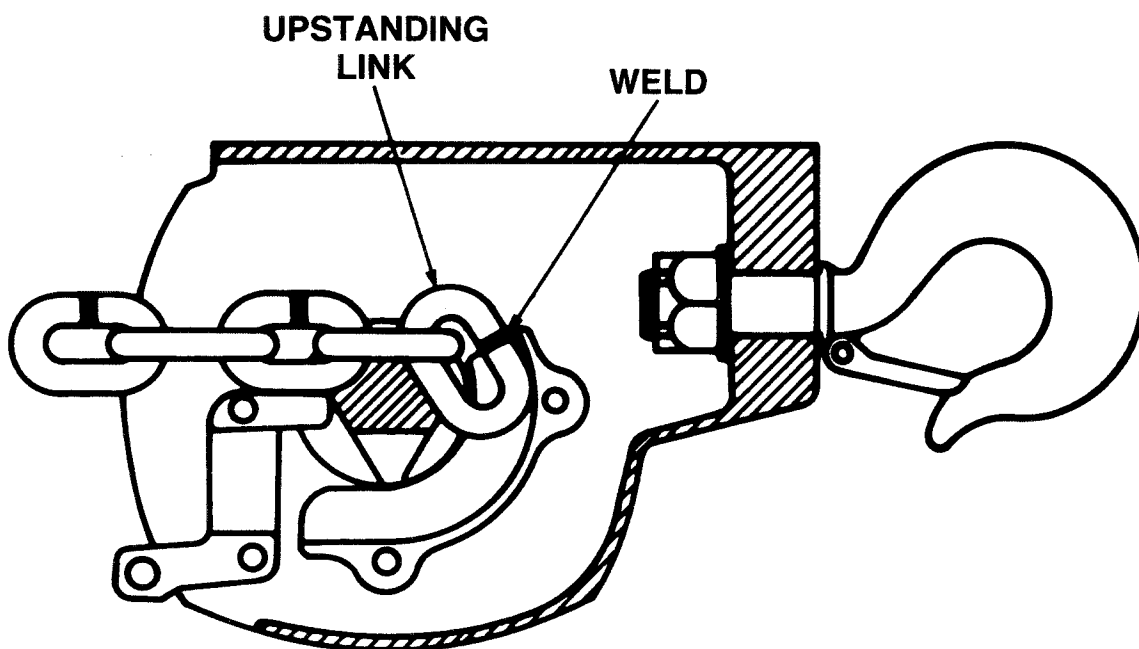

FIGURE 5-2 CHAIN REPLACEMENT

e. A capacity load should be applied to the chain for final inspection. Under a loaded condition check for cracks or defects which would not otherwise be visible. This completes the chain inspection.

### 5.4 THREAD STOP ADJUSTMENT.

When replacing the hand chain wheel and hand chain, mount the chain so that the weld on the chain link is out away from the hand chain wheel. Mount all items in reverse of what they were disassembled. The front disc must be in line with and touching the ratchet. The hand chain wheel is to be turned in a clockwise direction until ratcheting occurs. (Hand chain wheel should spin on freely.) **DO NOT BACK OFF!** Inspect to be sure that hub retaining ring is in place. Mount thread stop on spline so that the projection of the thread stop is  $\frac{1}{8}$ " minimum to  $\frac{1}{4}$ " maximum from the stop pin on the hand chain wheel. See Figure 5-3.

Americrane & Hoist Corp 1-800-652-1932

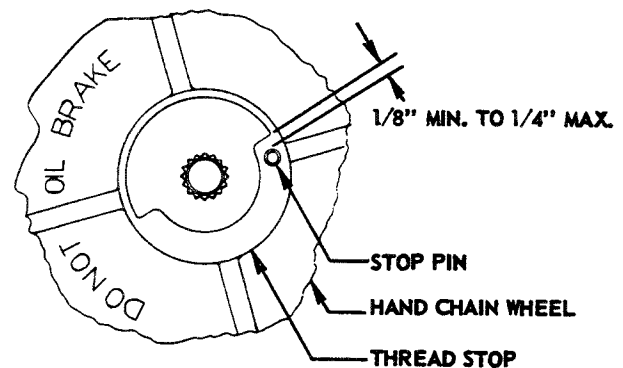
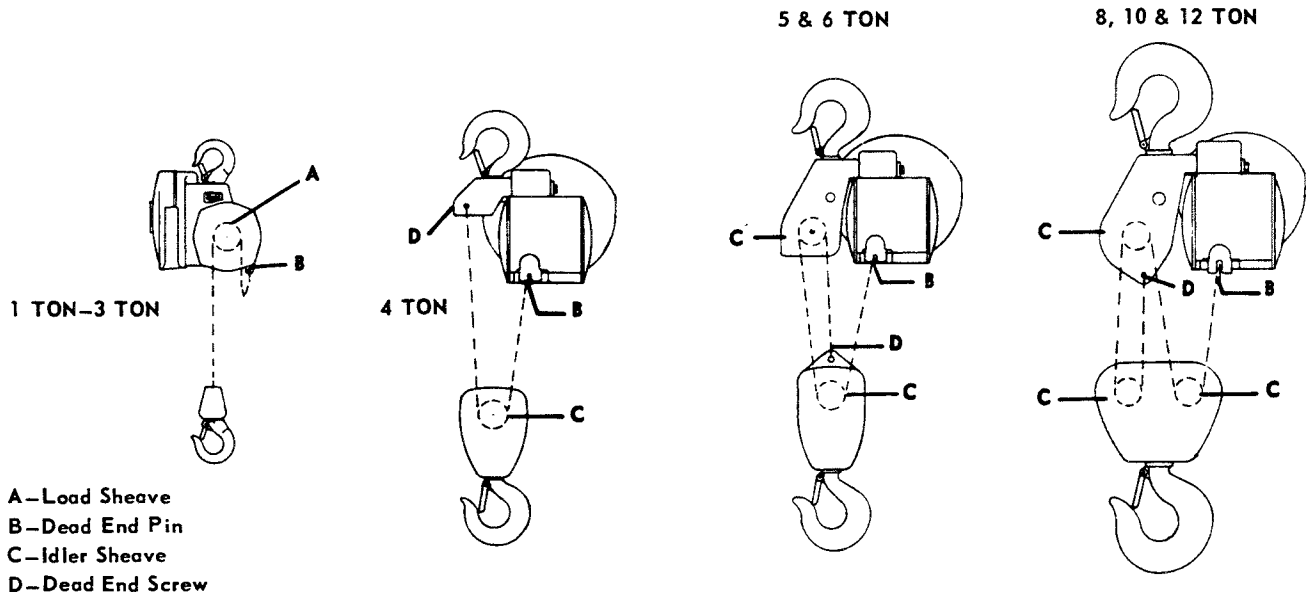

FIGURE 5-3 LOCATION OF THREAD STOP





**FIGURE 5-4 CHAIN REEVING**

Americrane & Hoist Corp 1-800-652-1932

INSPECTOR'S REPORT			
ITEM	REMARKS (LIST DEFICIENCIES AND RECOMMENDED ACTION)		
INSPECTORS SIGNATURE	DATE INSPECTED	APPROVED BY	DATE

**FIGURE 5-5 RECOMMENDED INSPECTORS REPORT**

**INSPECTION & MAINTENANCE CHECK LIST**  
**HAND OPERATED OVERHEAD CHAIN HOIST**

TYPE OF HOIST \_\_\_\_\_ CAPACITY (TONS) \_\_\_\_\_  
 LOCATION \_\_\_\_\_ ORIGINAL INSTALLATION DATE \_\_\_\_\_  
 MANUFACTURER \_\_\_\_\_ MANUFACTURER'S SERIAL NO. \_\_\_\_\_

ITEM	FREQUENCY OF INSPECTION			POSSIBLE DEFICIENCIES	OK	ACTION REQUIRED
	FREQUENT		PERIODIC			
	DAILY	MONTHLY	1-12 MO.			
Load Chain	•	•	•	Inadequate lubrication, excessive wear or stretch, cracked, damaged or twisted links, corrosion or foreign substance		
Brake Mechanism	•	•	•	Slippage or Excessive Drift		
Hooks	•	•	•	Excessive throat opening, bent or twisted more than 10 degrees, damaged hook latch, wear, chemical damage, worn hook bearing, Cracks (use dye penetrant, magnetic particle or other suitable detection method)		
Hook Retainers			•	Worn or damaged nuts, collars, pins, welds or riveting used to secure hook in load block or housing		
Brake Parts: Friction Discs  Pawl, Ratchet Pawl Springs Brake Hub Pawl Stud			• • • • •	Excessive wear, glazing, oil contamination Wear, Binding, Worn Bushing Breaks, corrosion or stretch Wear or damaged threads Excessive wear, pawl retention		
Sheaves, Hand Chain Wheel, Chain Attachments			•	Distortion, cracks, excessive wear		
Gearing			•	Inadequate lubrication, cracks, distortion, worn or broken teeth		
Bearings, Shafts			•	Inadequate lubrication, distortion, cracks, excessive wear		
Housing, Load Block, Outrigger			•	Cracks, distortion, loose bolts or nuts		
Nuts, Bolts, Rivets			•	Looseness, stripped or damaged threads		
Supporting Structure and Trolley (If Used)			•	Damage or wear which restricts ability to support imposed loads		
Capacity Plates Warning Labels			•	Missing, damaged or illegible		

NOTE: Refer to Maintenance and Inspection Sections of the Hoist Maintenance Manual for further details.

**PERIOD OF INSPECTION**

Frequent - Indicates items requiring inspection daily to monthly. Daily inspections may be performed by the operator if properly designated.

Periodic - Indicates items requiring inspection monthly to yearly. Inspections to be performed by or under the direction of a properly designated person. The exact period of inspection will depend on frequency and type of usage. Determination of this period will be based on the user's experience. It is recommended that the user begin with a monthly inspection and extend the periods to quarterly, semi-annually or annually based on his monthly experience.

**NOTE:** This inspection and maintenance check list is in accordance with our interpretation of the requirements of the Safety Standard for Overhead Hoists ANSI B30.16-1973. It is, however, the ultimate responsibility of the employer/user to interpret and adhere to the applicable requirements of this safety standard.

**FIGURE 5-6 INSPECTION AND MAINTENANCE CHECK LIST**

Americrane & Hoist Corp 1-800-652-1932

## SECTION VI SERIAL NUMBER AND PARTS LIST

### 6.1 SERIAL NUMBER

Each hoist has an individual stamped serial number which gives the basic hoist model, design series, number of chain strands, month and year manufactured.

Americrane & Hoist Corp 1-800-652-1932

### CB HOIST SERIAL NUMBER CODE CHART

SERIAL NUMBER EXAMPLE

**SER. CB 1 • 101 • D • KL • 1**

**BASIC HOIST MODEL**  
 1 — 1 Ton  
 2 — 1½ & 2 Ton  
 3 — 3 Ton

**SERIAL NUMBER**  
 This is a consecutive number starting with 101 at beginning of each calendar month for each basic model.

**DESIGN SERIES**  
 This letter indicates design series and will change with each major modification affecting interchangeability of parts.  
 "D" — Indicates "New Look" design — Refer to Engineering Data Sheet HD-302 for design series change information.

**NUMBER CHAIN STRANDS**  
 1. 1 Part — CB-1, CB-1½, CB-2 & CB-3  
 2. 2 Part — CB-4  
 3. 3 Part — CB-5 and CB-6  
 4. 4 Part — CB-8, CB-10 & CB-12  
**NOTE:** Warehouses shall be responsible for stamping this number on "LCX" Models chained at warehouse.

**YEAR DESIGNATOR**

D — 1968	S — 1980
E — 1969	T — 1981
F — 1970	U — 1982
G — 1971	V — 1983
H — 1972	W — 1984
J — 1973	X — 1985
K — 1974	Y — 1986
L — 1975	Z — 1987
M — 1976	A — 1988
N — 1977	B — 1989
P — 1978	C — 1990
R — 1979	

**MONTH DESIGNATOR**

A — January
B — February
C — March
D — April
E — May
F — June
G — July
H — August
J — September
K — October
L — November
M — December

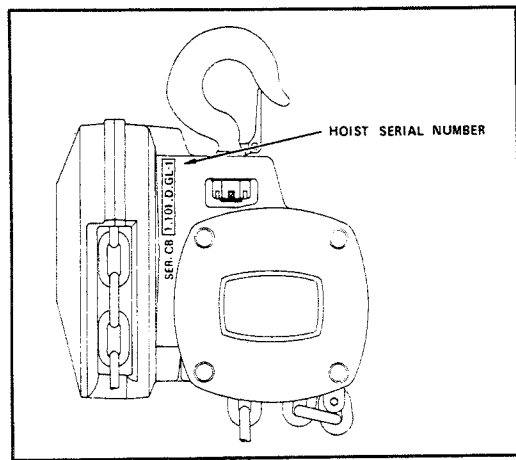

## 6.2 DESIGN SERIES

This letter indicates design series and will change with each major modification affecting interchangeability of parts. The following is review of all major design series.

### a. DESIGN SERIES B

Starting with this design series the hoist brake components were changed to give easier lowering effort on hand chain pull. This design series will be recognized by the 2½ inch inside diameter of the brake disc. The new brake parts are not individually interchangeable with old parts. The parts affected are:

Item No.	Part Name	Old Part No.	New Part No.
32	Hand Chain Wheel	CB-33-2 CB-33-1	CB-33-7 CB-33-6
7	Ratchet Assembly	CB-901-2	CB-7-3
33	Brake Hub	CB-34	CB-34-5
67	Brake Disc Front	CB-580-2	CB-580-6 (metal)
67A	Brake Disc Rear	CB-580-2	CB-580-6 (metal)

For change-over to the new assembly specify kit No. CB-910-1K For 1 Ton  
CB-910-2K For 1½ thru 12 Ton inclusive.

### b. DESIGN SERIES "D"

Starting with this design series the housing, covers and some other components were changed. The new parts are not interchangeable with old parts.

Item No.	Part name	Old Part No.	New Part No.
11	Housing	CB-18-3 CB-18-1 CB-18-2	CB-18-4 CB-18-5 CB-18-6
28	Handwheel Cover	CB-32-2 CB-32-1	CB-32-4 CB-32-5
25	Side Covers	CB-31 CB-31-1 CB-31-2	CB-31-3 CB-31-4 CB-31-5
68	Capacity Plates	CB-675-10 CB-675 CB-675-1 CB-676-6 CB-675-4 CB-765-2 CB-675-3 CB-675-7 CB-675-5	CB-683-1 CB-683-2 CB-683-4 CB-683-5 CB-683-6 CB-683-7 CB-683-3 CB-683-8 CB-683-9

### c. DESIGN SERIES "E"

Starting with this design series the hoist brake disc and ratchet assembly were changed to a one-part design.

Item No.	Part Name	Old Part No.	New Part No.
33	Brake Hub	CB-34-3	CB-34-4
7	Ratchet Assembly	CB-902-3	CB-901-4
67	Brake Disc Front	CB-580-5	Included in CB-901-4
67A	Brake Disc Rear	CB-580-4	Included in CB-901-4

### d. DESIGN SERIES "F"

Starting with this design series the pawl stud and pawl retention method was changed.

Item No.	Part Name	Old Part No.	New Part No.
18	Pawl Stud	CB-26-3	CB-26-3RP
82	Cotter Pin	H-5025	
82	Retaining Ring		H-5568

CB-26-3RP includes retaining ring H-5568 and is available for repair of all design series.

### e. DESIGN SERIES "G"

This design series affects the CB-3, CB-10 and CB-12 only.

Item No.	Part Name	Old Part No.	New Part No.
8	Load Sheave	CB-16-2	CB-16-7
13	Load Chain	CB-19	19J3

The new part numbers are interchangeable with old and can be used on all design series.

### f. DESIGN SERIES "H"

Starting with this design series ratchet assembly and brake was redesigned.

Item No.	Part Name	Old Part No.	New Part No.
33	Brake Hub	CB-34-4	CB-34-5
7	Ratchet Assembly	CB-901-4	CB-7-3
67	Brake Disc Front	Included in CB-901-4	CB-580-6
67A	Brake Disc Rear	Included in CB-901-4	CB-580-6

To change-over from design series "E" "F" and "G" to the new brake specify kit number CB-910-3K for all capacities.

## 6.3 HOW TO ORDER REPLACEMENT PARTS

When ordering parts or requesting information concerning your CB hoist, always include the hoist model number and serial number with the item and part numbers required. NOTE: Repair parts are available only from Coffing distributors or authorized repair facilities. It is recommended that repair parts orders be directed to the authorized repair facility nearest you.

## 6.4 PARTS LIST

Each part in the hoist is keyed with an item number on the exploded illustrations. Once the item number and part name has been identified the part number can be selected by capacity and design series.

The following is an index for the design series column. No symbol in this column, part is used on all series.

- 1 Part used on all hoist prior to design series "B"
- 2 Part used on all design series "B" and later hoist
- 3 Part used on all design series "B" through design series "D"
- 4 Part used on all hoist prior to design series "D"
- 5 Part used on all design series "D" and later hoist
- 6 Parts used on all design series "E" through design series "G"
- 7 Parts used on all design series "F" and later hoist
- 8 Parts used on all design series "H" and later hoist
- 9 Parts used on all design series "B" through "D" and "H" and later hoist

\*Bottom hook assembly changed from a smooth shank hook ¼" diameter pin and collar to a hex slotted nut, ⅜" diameter pin and threaded shank hook. Old style part numbers are as listed. Hook collar JF-108 Driv-Lok Pin H-5122, smooth shank hook CA-3-6

Americrane & Hoist Corp 1-800-652-1932

ITEM NO.	PART NAME	NO. REQ.	CAPACITY TONS	DESIGN SERIES	PART NO.
1	Top Hook with Latch	1	1 1½ & 2 3 & 4 5 & 6 8 10 & 12		MA-3-10S SHL-5 SHL-8 SHL-15 SHL-16 SHL-17
2	Top Hook Nut	1	1 1½ & 2 3 & 4 5 & 6 8, 10 & 12		H-3986-P H-3922-P H-3924-P H-3925-P H-3923-P
3	Top Hook Pin	1	1 1½ & 2 3 & 4 5 & 6 8, 10 & 12		H-5251 H-5243 H-5235 H-5256 H-5257
4	Bottom Hook with Latch	1	1 1½ & 2 3 4 5 & 6 8 10 & 12		3JG20S SHL-26 SHL-14 SHL-8 SHL-15 SHL-16 SHL-17
5	Bottom Hook Nut	1	1 1½ & 2 3 4 5 & 6 8, 10 & 12		H-3986-P H-3991-P H-3922-P H-3924-P H-3925-P H-3923-P
6	Bottom Hook Pin	1	1 1½ & 2 3 4 5 & 6 8, 10 & 12		H-5159 H-5232 H-5243 H-5235 H-5256 H-5257
7	Ratchet Assembly	1	All	1 3 6 8	CB-910-2 CB-901-3 CB-901-4 CB-7-3
8	Load Sheave	1	1 1½ & 2 4, 5, 6 & 8 3, 10 & 12		CB-16-5 CB-16-6 CB-16-6 CB-16-7
9	Sheave Nut	1	1 1½ & 2 4, 5, 6 & 8 3, 10 & 12		H-3681 H-3682 H-3682 H-3702
10	Sheave Lockwasher	1	1 1½ & 2 4, 5, 6 & 8 3, 10 & 12		H-4067 H-4068 H-4068 H-4069
11	Housing	1	1 1½ & 2 1½ & 2 4, 5, 6 & 8 4, 5, 6 & 8 3, 10 & 12 3, 10 & 12	4 5 4 5 4 5 4 5	CB-18-3 CB-18-4 CB-18-1 CB-18-5 CB-18-1 CB-18-5 CB-18-2 CB-18-6
13	Load Chain (Price Per Lineal Foot)	—	1 1½ & 2 4, 5, 6 & 8 3, 10 & 12		C-19-9 C-19-12 C-19-12 19J3
14A	Swivel Frame (For Bolt Head)	1	1 1½ 2 3		JF-20-2 CB-20-4 CB-21-3 CB-21-1
14B	Swivel Frame (For Bolt Threads)	1	1 1½ 2 3		JF-20-3 CB-20-5 CB-21-2 CB-21
15	Swivel Frame Screw	2	1½, 2 & 3		H-2313-P
16	Swivel Frame Nut	2	1½, 2 & 3		H-3943-P
17	Pawl (Inc. CB-180 Pin)	1	All	2	CB-902-3
18	Pawl Stud (Inc. Item 82)	1	All		CB-26-3RP
19	Pawl Lockwasher	1	All		H-4065

ITEM NO.	PART NAME	NO. REQ.	CAPACITY TONS	DESIGN SERIES	PART NO.
21	Sheave (Load Block & Outtrigger)	1 2 3 3	4 5 & 6 8 10 & 12		CB-28 CB-28 CB-28 CB-28-1
22	Load Block Frame	2	4 5 & 6 8 10 & 12		CB-30 CB-30-4 CB-30-2 CB-30-3
23	Load Block Screw	2 2 4	4 5 & 6 8, 10 & 12		H-2411-P H-2419-P H-2419-P
24	Load Block Nut	2 2 4	4 5 & 6 8, 10 & 12		H-3965-P H-3966-P H-3966-P
25	Side Cover	2	1 1½ & 2 1½ & 2 4, 5, 6 & 8 4, 5, 6 & 8 3, 10 & 12 3, 10 & 12	4 5 4 5 4 5 4 5	CB-31 CB-31-3 CB-31-1 CB-31-4 CB-31-1 CB-31-4 CB-31-2 CB-31-5
26	Side Cover Screw	8	All		H-1106-P
27	Side Cover Lockwasher	8	All		H-4062-P
28	Hand Chain Wheel Cov.	1	1 1½, 2, 3, 4, 5, 1½, 2, 3, 4, 5, 6, 8, 10 & 12 6, 8, 10 & 12	4 5 4 5 4 5	CB-32-2 CB-32-4 CB-32-1 CB-32-5 CB-32-1 CB-32-5
29	H.C. Wh. Cover Screw	3	1 1 1½, 2, 3, 4, 5 6, 8, 10 & 12	4 5	H-1843-P H-1847 H-1107-P H-1107-P
30	H.C. Wh. Cover Lockwasher	3	1 1½, 2, 3, 4, 5 6, 8, 10 & 12		H-4062-P H-4066-P H-4066-P
31	H.C. Wh. Cover Pin	2	All		H-5382
32	Hand Chain Wheel	1	1 1½, 2, 3, 4, 5 1½, 2, 3, 4, 5 6, 8, 10 & 12 6, 8, 10 & 12	1 2 1 2 1 2	CB-33-2 CB-33-7 CB-33-1 CB-33-6 CB-33-1 CB-33-6
33	Hub	1	All		CB-34 CB-34-3 CB-34-4 CB-34-5
34	Hub Retaining Ring	1	All		H-5502
35	Chain Guide	1	1 1½, 2, 4, 5 6 & 8 3, 10 & 12		CB-36 CB-36-1 CB-36-1 CB-36-3
36	Roll Pins	2	1 1½ & 2 4, 5, 6 & 8 3, 10 & 12		H-5242 H-5254 H-5254 H-5255
37	Shedder	1	1 1½ & 2 4, 5, 6 & 8 3, 10 & 12		CB-37-3 CB-37-4 CB-37-4 CB-37-5
38	Dead End Pin	1	1 1½ & 2 4, 5, 6 & 8 3, 10 & 12		H-5132-P H-5133-P H-5133-P H-5134-P
39	Roll Pin	2	1 1½ & 2 4, 5, 6 & 8 3, 10 & 12		H-5242 H-5247 H-5247 H-5248
40	Outtrigger	1	4 5 & 6 8 10 & 12		CB-42 CB-42-4 CB-42-2 CB-42-3
41	Outtrigger Ret. Ring	1	5, 6 & 8 10 & 12		H-5514 H-5515

Americrane & Hoist Corp 1-800-652-1932

ITEM NO.	PART NAME	NO. REQ.	CAPACITY TONS	DESIGN SERIES	PART NO.
42	Hand Chain (Price Per Lineal Foot)	—	All		53-A
43	Pawl Spring	1	All		B-67
44	Pawl Spring Roll Pin	1	All		H-5235
45	Load Block Shaft	1 2 2	4, 5 & 6 8 10 & 12		CB-100 CB-100 CB-100-1
46	Outrigger Shaft	1	5, 6 & 8 10 & 12		CB-100-2 CB-100-3
47	Shaft Pin (Load Block & Outrigger)	1 2 3 3	4 5 & 6 8 10 & 12		H-5235 H-5235 H-5235 H-5256
48	Keeper	1	4, 5, 6 & 8 10 & 12		CB-102 CB-102-1
49	Adapter Bearing	1	10 & 12		CB-103-2
51	Bearing Retainer	1	1 1½ & 2 4, 5, 6 & 8 3, 10 & 12		CB-250 CB-250-1 CB-250-1 CB-250-2
52	Bearing Retainer Screw	4 6 6 8	1 1½ & 2 4, 5, 6 & 8 3, 10 & 12		H-2952 H-2952 H-2952 H-2952
53	Thread Stop	1	All		CB-251
54	Thread Stop Pin	1	1 1½, 2 & 3 4, 5, & 6 8, 10 & 12		H-5239 H-5263 H-5263 H-5263
55	Top Hook Washer	1	1 1½ & 2 3 & 4 5 & 6 8, 10 & 12		JF-260 CB-252 CB-252-1 CB-252-3 CB-252-4
56	Bottom Hook Washer	1	3 4 5 & 6 8		CB-253 CB-252-2 CB-252-3 CB-252-4
57	Gear Shim	AR	1 1½, 2, 4 & 5 6 & 8 3, 10 & 12		CB-254 CB-254-1 CB-254-1 CB-254-2
58	Washer	2 4 6 6	4 5 & 6 8 10 & 12		CB-255 CB-255 CB-255 CB-256
59	Gear	1	1 1½ & 2 4, 5, 6 & 8 3, 10 & 12		CB-480-3 CB-482-3 CB-482-3 CB-484-3
60	Pinion Shaft	1	1 1½ & 2 4, 5, 6 & 8 3, 10 & 12		CB-481-1 CB-483-2 CB-483-2 CB-485-2
61	Bearing	3	1 1½, 2 & 4 5, 6 & 8 3, 10 & 12		CB-504 CB-504-1 CB-504-1 CB-504-2
62	Bearing	1	All		CB-505
63	Thrust Bearing	1	1 1½ & 2 3 4 5 & 6 8 10 & 12		JF-510 JF-511 CB-510 CB-511 CB-511-1 CB-511-2 CB-511-3
64	Sheave Roller Bearing	2 4 6 6	4 5 & 6 8 10 & 12		CB-521 CB-521 CB-521 CB-521-1
67	Brake Disc (Front)	1	All	1 9	CB-580-2 CB-580-6
67A	Brake Disc (Rear)	1	All	1 9	CB-580-2 CB-580-6

ITEM NO.	PART NAME	NO. REQ.	CAPACITY TONS	DESIGN SERIES	PART NO.
68	Capacity Plate (Hoist)	1	5, 6 & 8 10 & 12	1	CB-684
				1½	MA-675
				1½	CB-683-1
				2	CB-675
				2	CB-683-2
				3	CB-675-3
				3	CB-683-3
				4	CB-675-1
				4	CB-683-4
				5	CB-675-6
				5	CB-683-5
				6	CB-675-4
6	CB-683-6				
8	CB-675-2				
8	CB-683-7				
10	CB-675-7				
10	CB-683-8				
12	CB-675-5				
12	CB-683-9				
69	Capacity Plate (Load Block)	2	5 6 10 12		CB-675-8 CB-675-9 CB-675-7 CB-675-5
70	Drive Screw (Cap. Plate)	4 8	1½, 2, 3, 4, 8 5, 6, 10 & 12		H-2861-P H-2861-P
71	Swivel Screw	1	1 1½ 2 3		JF-700 CB-700-1 CB-700-1 CB-700
72	Lockwasher (Swivel Screw)	1	1½ 2 3		H-4135 H-4135 H-4137
73	Dead End Screw	1	4 & 8 5 & 6 10 & 12		CB-700-1 CB-700-2 CB-700
74	Lockwasher (Dead End)	1	4 & 8 10 & 12		H-4135 H-4137
75	Nut (Dead End)	1	5 & 6		H-3965-P
76	Outrigger Screw	2	4 thru 12		CB-701
77	Lockwasher (Outrigger Screw)	2	4 thru 12		H-4063-P
78	Torsion Spring (Pawl)	1	All		CB-312-1
80	Flat Washer		All		H-4216
81	Top & Botton Latch Kit	2	1 1½ & 2 3, 4, 5 & 6 8 10 & 12		H-7540 H-7544 H-7545 H-7546 H-7547
82	Retaining Ring	1	All	7	H-5568
83	Warning Label	1 1 2	1 1½, 2 & 3 4 thru 12		687-K-1 687-K-2 687-K-4
IN ADDITION TO THE PARTS LISTED ABOVE THE FOLLOWING ASSEMBLIES MAY BE PROCURED.					
	PART NAME		CAPACITY TONS		PART NO.
	Load Block-Shaft (Items 45 & 47)		4, 5, 6 & 8 10 & 12		CB-903 CB-903-1
	Outrigger Shaft (Items 46 & 47)		5, 6, & 8 10 & 12		CB-903-2 CB-903-3
	Sheave & Bearing (Items 21 & 64)		4, 5, 6 & 8 10 & 12		CB-916 CB-916-1
	Bottom Hook & Bearing (Items 4, 5, 6, 49, 50, 56, 63 & 81)		1 1½ 2 3 4 5 & 6 8 10 & 12		3JG20S CB-912-11 CB-912-11 CB-912-12 MA-912-3 CB-912-14 CB-912-15 CB-912-16
	Load Block (Items 22, 23, 24, 58, Load Block Shaft Assby., Bottom Hook Assby. & Sheave & Bearing Assby.)		1 4 5 & 6 8 10 & 12		913JG4AS CB-914-5 CB-914-6 CB-914-7 CB-914-8
	Outrigger (Items 1, 2, 3, 40, 41, 55, 58, Outrigger Shaft Assby. & Sheave & Bearing Assby.)		4 5 & 6 8 10 & 12		CB-900 CB-900-4 CB-900-2 CB-900-3

Americrane & Hoist Corp 1-800-652-1932

## SECTION VII EXPLODED ILLUSTRATION

The following exploded drawings provide a complete list of parts used in the standard CB hoist (shown in Table 1). Since different models and capacities are covered by this manual the item number and parts list will show each different part number with sufficient information to allow the selection of the correct part number.

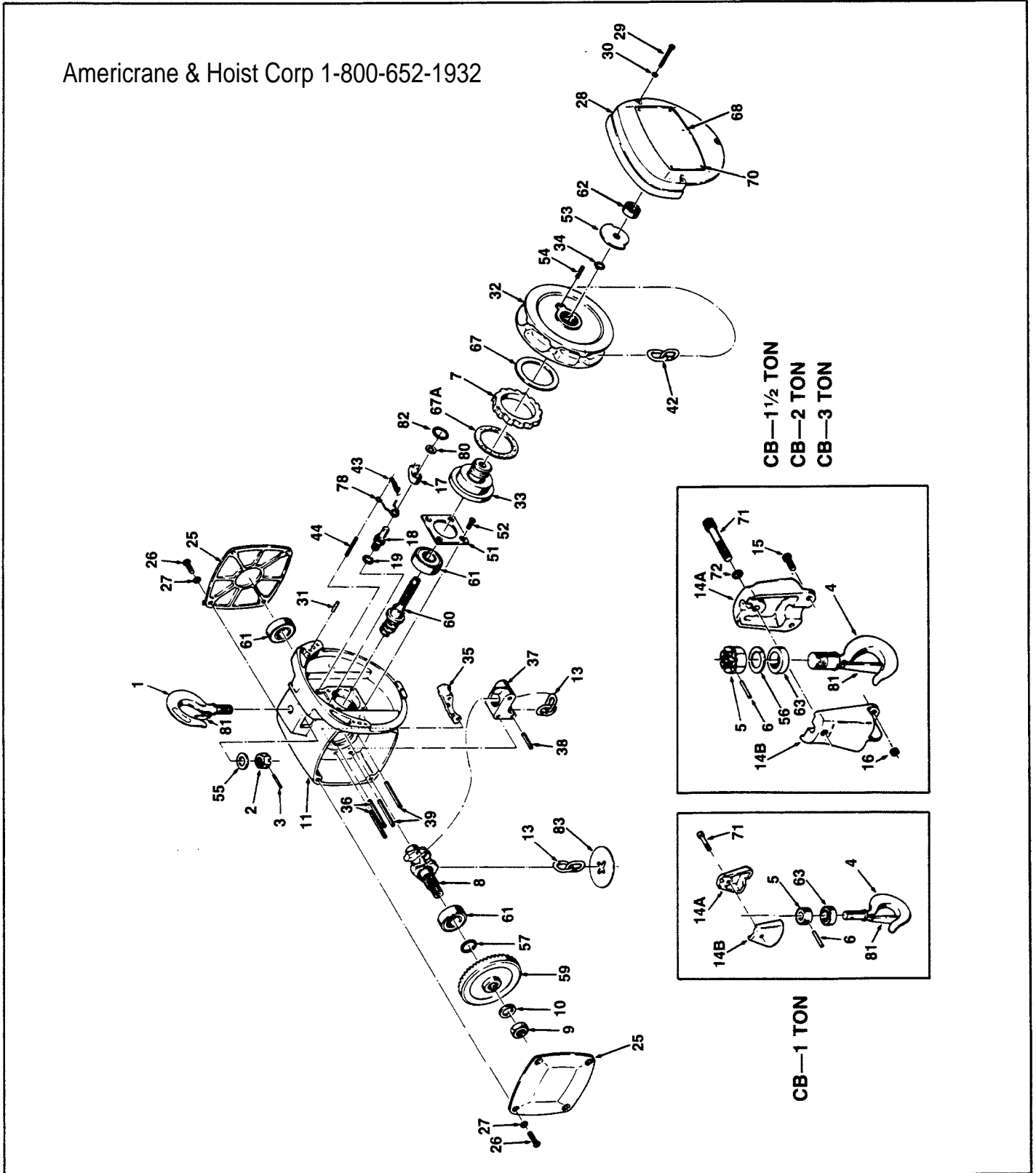

FIGURE 7-1 CB-1 TON, CB-1 1/2 TON, CB-2 TON, CB-3 TON

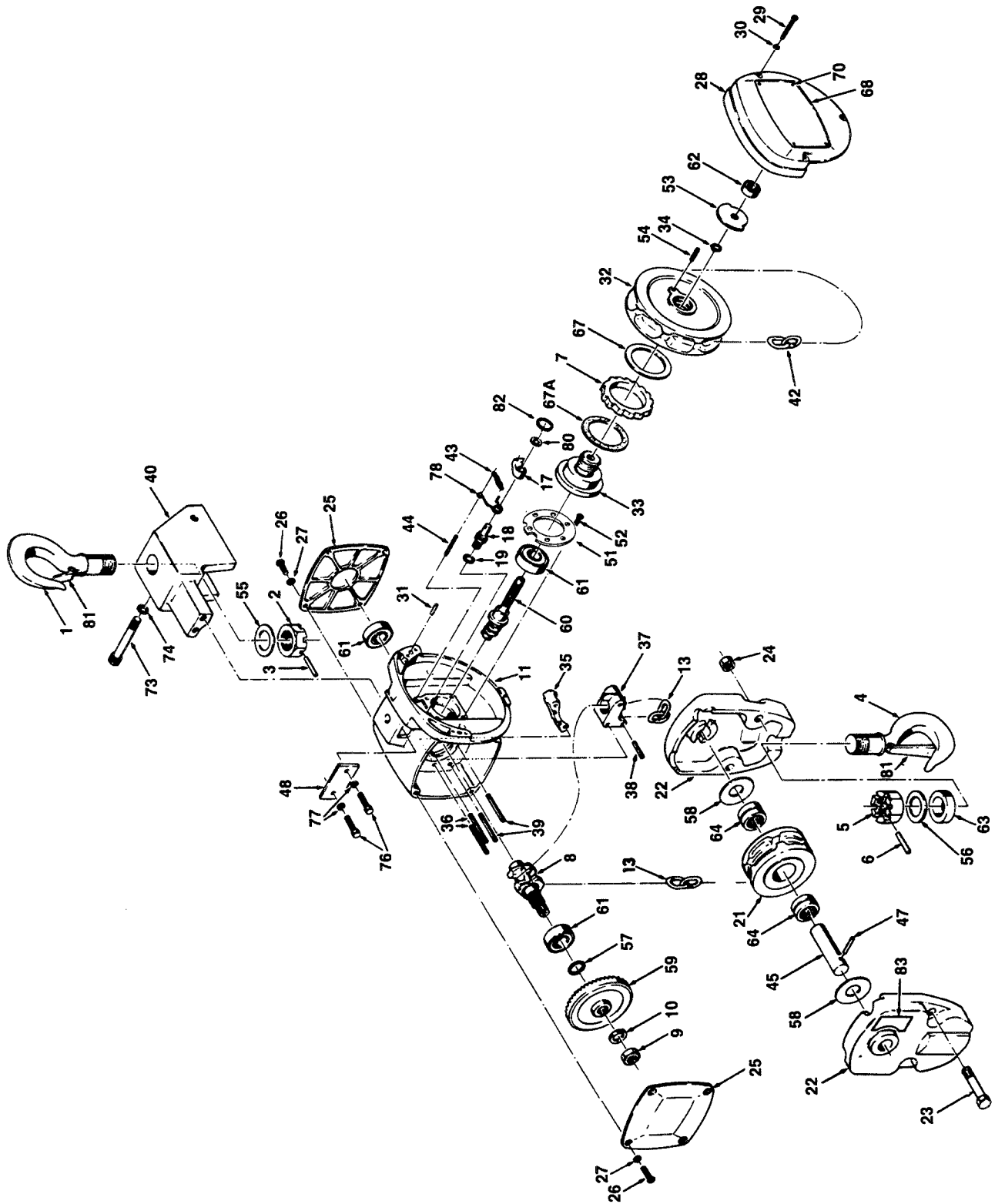

FIGURE 7-2 CB-4 TON



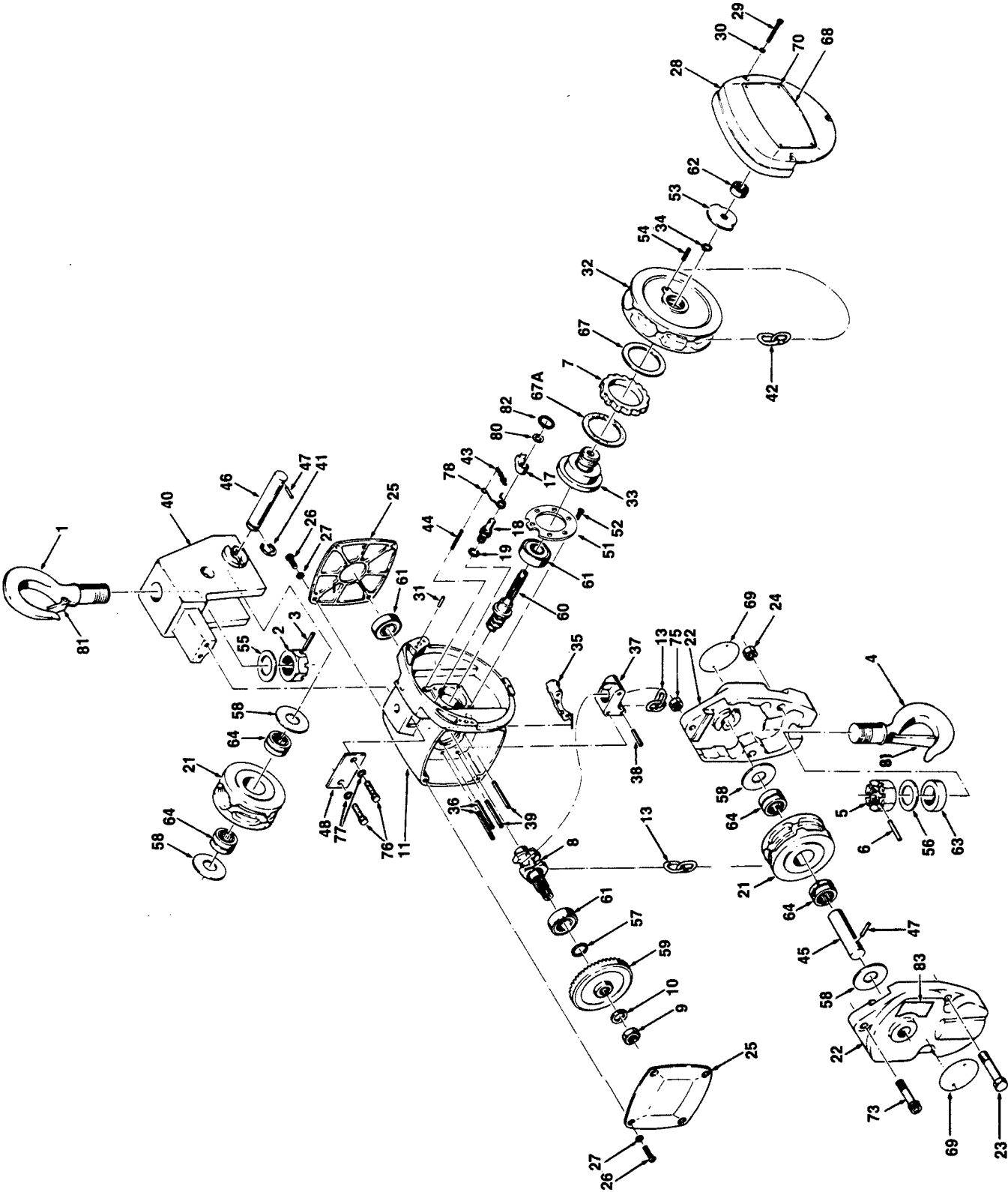

FIGURE 7-3 CB-5 TON, CB-6 TON HOIST

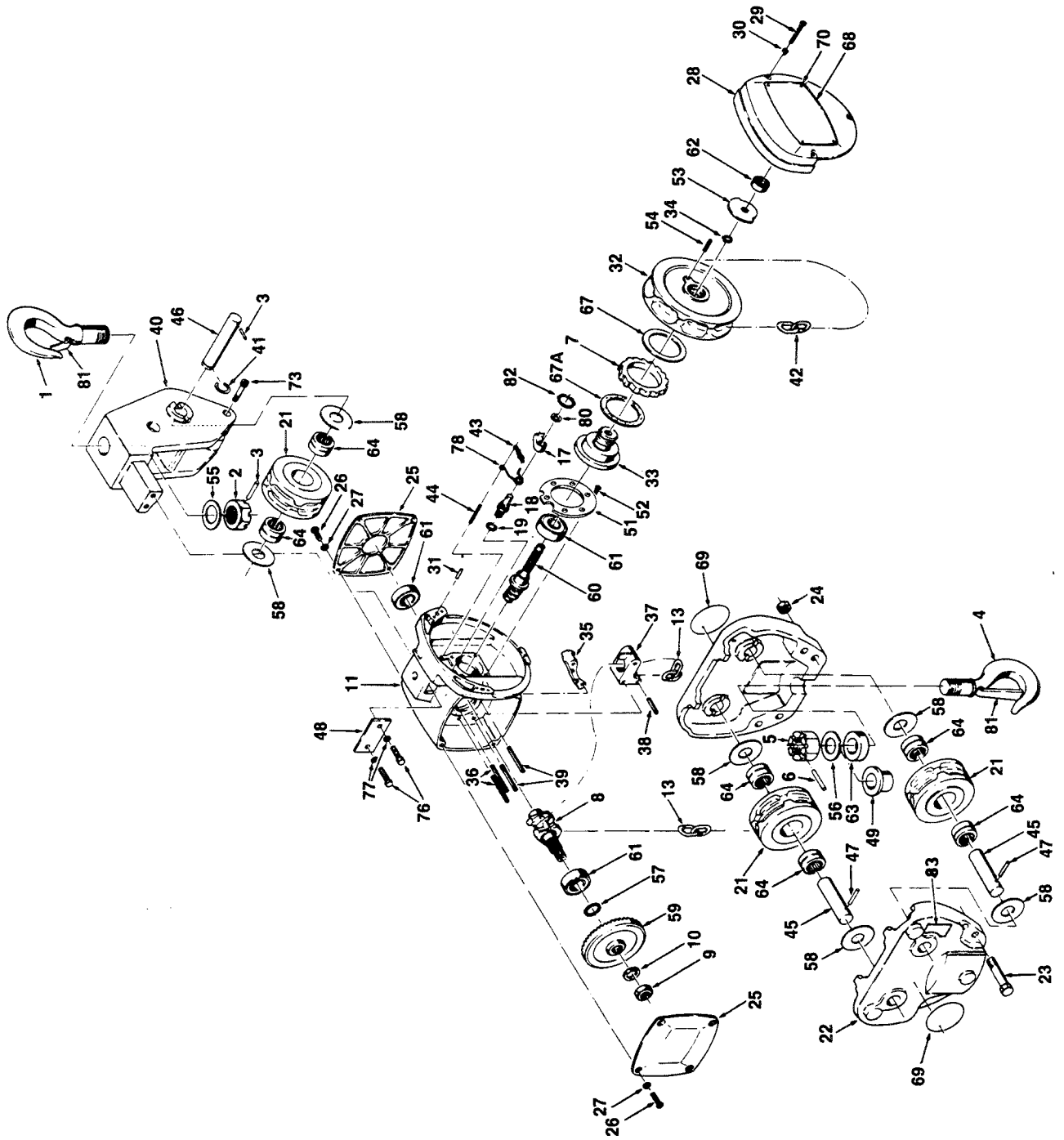

FIGURE 7-4 CB-8-10-12 TON HOIST

## DO'S AND DO NOT'S

### Hand Chain Manually Operated Chain Hoists

The following warnings and operating practices have been taken from American National (Safety) Standard ANSI B30.16 and are intended to avoid unsafe hoisting practices which might lead to personal injury or property damage.

These recommendations apply to all hand chain manually operated chain hoists for vertical lifting service involving material handling of freely suspended unguided loads.

#### WARNING: TO AVOID INJURY

1. DO read ANSI B30.16 Safety Standard for Overhead Hoists and the Hoist Manufacturer's Operating and Maintenance Instructions.
2. DO be familiar with hoist operating controls, procedures, and warnings.
3. DO make sure the hoist suspension hook is securely attached to a suitable support.
4. DO maintain firm footing or be otherwise secured when operating hoist.
5. DO make sure that load slings or other approved attachments are properly sized and seated in the hook saddle.
6. DO make sure the hook latch, if used, is closed and not supporting any part of the load.
7. DO make sure that load is free to move and will clear all obstructions.
8. DO take up slack carefully, check load balance, lift a few inches, and check load holding action before continuing.
9. DO make sure all persons stay clear of the suspended load.
10. DO avoid swinging of load or load hook.
11. DO protect load chain from weld spatter or other damaging contaminants.
12. DO promptly report any malfunction, unusual performance, or damage, of the hoist.
13. DO inspect hoist regularly, replace damaged or worn parts, and keep appropriate records of maintenance.
14. DO use the hoist manufacturer's recommended parts when repairing a hoist.
15. DO use hook latches wherever possible.
16. DO apply lubricant to load chain as recommended by the Hoist Manufacturer.
17. DO NOT lift more than rated load.
18. DO NOT use the hoist load limiting device to measure the load.
19. DO NOT use damaged hoist or hoist that is not working correctly.
20. DO NOT use hoist with twisted, kinked, damaged, or worn chain.
21. DO NOT lift a load unless chain is properly seated in chain wheel(s) or sprocket(s).
22. DO NOT use load chain as a sling or wrap load chain around the load.
23. DO NOT lift a load if any binding prevents equal loading on all supporting chains.
24. DO NOT apply the load to the tip of the hook.
25. DO NOT operate unless load is centered under hoist.
26. DO NOT operate hoist with other than manual power.
27. DO NOT permit more than one operator to pull on a single hand chain at one time.
28. DO NOT allow your attention to be diverted from operating the hoist.
29. DO NOT operate hoist beyond limits of load chain travel.
30. DO NOT use hoist to lift, support, or transport people.
31. DO NOT lift loads over people.
32. DO NOT leave a suspended load unattended unless specific precautions have been taken.
33. DO NOT allow sharp contact between two hoists or between hoist and obstructions.
34. DO NOT allow the chain or hook to be used as a ground for welding.
35. DO NOT allow the chain or hook to be touched by a live welding electrode.
36. DO NOT remove or obscure the warnings on the hoist.
37. DO NOT adjust or repair a hoist unless qualified to perform hoist maintenance.
38. DO NOT attempt to lengthen the load chain or repair damaged load chain.

Reprinted with the permission of the Hoist Manufacturing Institute.

Americrane & Hoist Corp 1-800-652-1932

# COFFING<sup>®</sup> HOISTS

## WARRANTY

**E**very hoist is thoroughly inspected and tested prior to shipment from the factory. Should any problem develop, return the complete hoist prepaid to your nearest Coffing Hoists Authorized Warranty Repair Station. If inspection reveals that the problem is caused by defective workmanship or material, repairs will be made without charge and the hoist will be returned, transportation prepaid. This warranty does not apply where: **(1)** deterioration is caused by normal wear, abuse, improper or inadequate power supply, eccentric or side loading, overloading, chemical or abrasive actions, improper maintenance, or excessive heat; **(2)** problems resulted from repairs,

modifications, or alterations made by persons other than factory or Coffing Authorized Warranty Repair Stations personnel; **(3)** the hoist has been abused or damaged as a result of an accident; **(4)** repair parts or accessories other than those supplied by Coffing Hoists are used on the hoist. Equipment and accessories not of the seller's manufacture are warranted by the manufacturer.

**Except as stated herein, Coffing Hoists makes no other warranties, express or implied, including warranties or merchantability and fitness for a particular purpose.**

## WARNING

### Overloading and Improper Use Can Result In Injury

#### To Avoid Injury:

- Do not exceed working load limit, load rating, or capacity.
- Do not use to lift people or loads over people.
- Use only alloy chain and attachments for overhead lifting.
- Read and follow all instructions.

**Coffing Hoists • Country Club Road • P.O. Box 779 • Wadesboro, NC 28170 USA**  
**Customer Service: Tel. (800) 477-5003 (704) 694-2156 • FAX (800) 374-6853 (704) 694-6829**